

# MS-2D

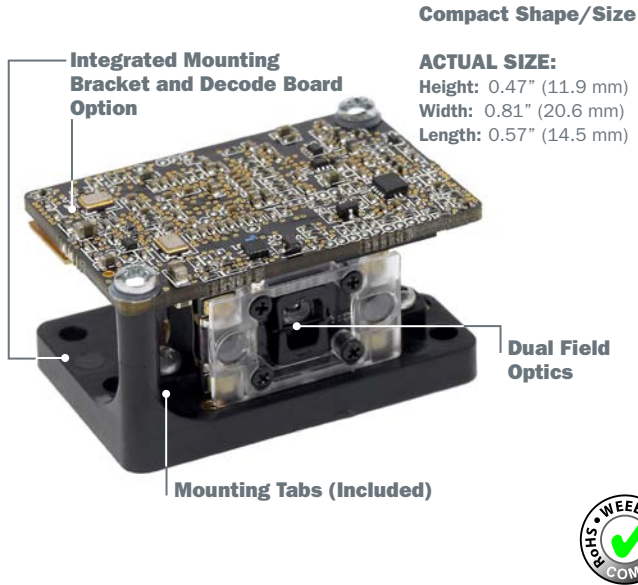

## 2D Imaging Engine

The MS-2D engine is an ultra-compact barcode imaging system that can be easily integrated into any device. Featuring advanced technologies for decoding, the MS-2D engine includes a dual optical field for reliable reading of both large 1D barcodes and high density 2D symbols.

Designed specifically for embedded applications, the MS-2D engine provides the best performance available for reading 1D/2D symbols and direct part marks at very close range.

### MS-2D Engine: At a Glance

- Ultra-fast Microprocessor
- Dual Field Optics for Both Wide and High Density Fields
- X-Mode Technology for High Performance Decoding
- USB 2.0, RS-232 Interface Options
- Low 5V Power Draw



ESP® Easy Setup Program: Single-point software provides quick and easy setup and configuration of all Microscan readers.

For more information on this product, visit [www.microscan.com](http://www.microscan.com).

#### Compact & Lightweight

The MS-2D decode board has a footprint of 1.54" W by 0.98" D by 0.30" H (39.0 mm W by 24.9 mm D by 7.6 mm H) and weighs only 0.10 oz. (2.8 g).

#### Reading Capabilities

The MS-2D engine with X-Mode decoding algorithms can easily read the most damaged or difficult codes and symbols, including direct part marks.

#### Easy Setup

ESP software provides easy configuration of the MS-2D engine, including selectable trigger and symbology setting.



#### Multiple Configurations

A variety of mounting features are available including tabs, blind through holes, and mounting brackets. Configuration options include integrated decode board and mounting bracket, or low profile tab mount with remote decode board.

#### Application Examples

- Clinical instruments
- Medical devices
- Electronics assembly
- Kiosks and bank ATMs

### MS-2D Engine: Available Codes

Linear	All Standard 	Postal Codes 		
Stacked	MicroPDF 	PDF417 	GS1 Databar 	
2D	Data Matrix 	QR 	Micro QR 	Aztec 

# MS-2D ENGINE SPECIFICATIONS AND OPTIONS

## ENGINE WITH TABS

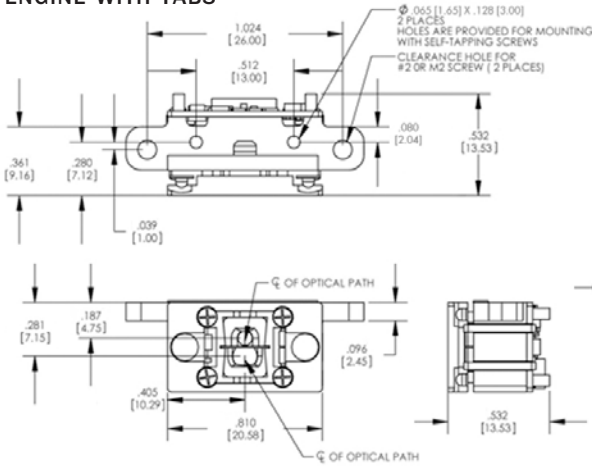

## INTEGRATED UNIT

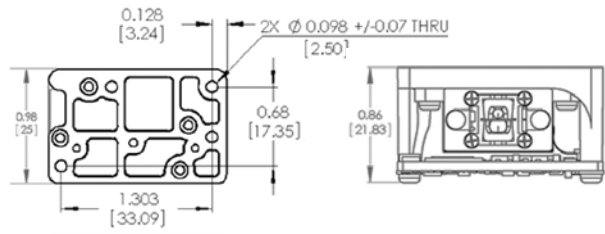

## DECODE BOARD

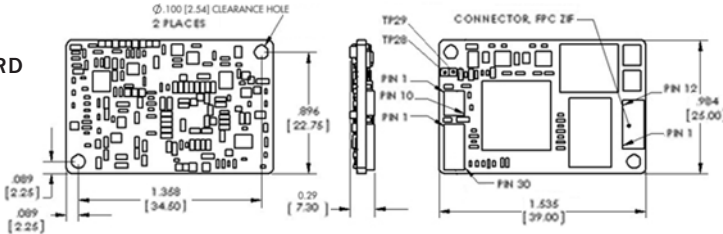

## READ RANGE GRAPH

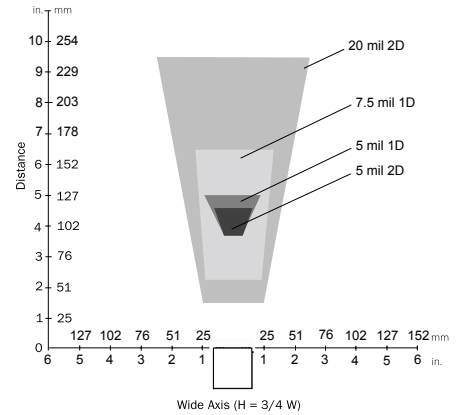

Note: Inches [millimeters]. Nominal dimensions shown. Typical tolerances apply.

## MECHANICAL (ENGINE)

**Height:** 0.47" (11.9 mm)  
**Width:** 0.81" (20.6 mm)  
**Length:** 0.57" (14.5 mm)  
**Weight (Without Mounting Tabs):** 0.09 oz. (2.6 g)

## MECHANICAL (DECODE BOARD)

**Height:** 1.54" (39.0 mm)  
**Width:** 0.98" (24.9 mm)  
**Length:** 0.30" (7.6 mm)  
**Weight:** 0.10 oz. (2.8 g)

## MECHANICAL (INTEGRATED UNIT)

**Height:** 1.54" (39.0 mm)  
**Width:** 0.98" (24.9 mm)  
**Length:** 0.86" (21.8 mm)  
**Weight:** 0.91 oz. (25.7 g)

## LIGHT SOURCE

**Type:** High output red LED illumination  
**Target Beam:** Blue LED

## LIGHT COLLECTION OPTIONS

**Sensor:** CMOS 1.2 Megapixel  
**Optical Resolution:** 960 x 640 pixels, both high density and wide

## SCANNING PERFORMANCE

**Pitch:** ± 60° (from front to back)  
**Skew:** ± 60° from plane parallel to symbol (side-to-side)  
**Tilt:** ± 180°

## Print Contrast Resolution:

25% (1D symbologies), 35% (2D symbologies) absolute dark/light reflectance differential, measured at 650 nm

## COMMUNICATION

**Interface:** USB 2.0, RS-232 TTL  
**Memory:** 128MB Flash ROM, 32MB RAM

## SYMBOLOGIES

**2D Symbologies:** Data Matrix (ECC 0-200), QR Code, Micro QR Code, Aztec Code  
**Stacked Symbologies:** PDF417, Micro PDF417, GS1 Databar (Composite & Stacked)

**Linear Barcodes:** Code 39, Code 128, BC 412, I2 of 5, UPC/EAN, Codabar, Code 93, Pharmacode, PLANET, PostNet, Japanese Post, Australian Post, Royal Mail, Intelligent Mail, KIX

## ENVIRONMENTAL CHARACTERISTICS

**Operating Temperature:** -20° to 55° C (-4° to 131° F)  
**Storage Temperature:** -30° to 65° C (-22° to 150° F)

## Relative Humidity:

5% to 95% (non-condensing)

**Ambient Light Immunity:** Sunlight: Up to 9,000 ft-candles/96,800 lux

**Shock:** Withstands multiple drops of 6' (1.8 m) to concrete in an enclosed housing

## INDICATORS

**Symbol Locator:** Blue LED targeting beam  
**Beeper:** Good read

## ELECTRICAL

**Power:** 5 VDC  
**Typical:** 303 mA **Idle:** 57 mA **Sleep:** 1.6 mA

## CE STANDARDS

**Emissions:** EN 55022:2006 Class B Limits; ICES-003  
**LED Safety:** EN 60825-1: 1994+A1+A2 Class 1

## READ RANGE TABLE

Narrow-Bar	Read Range
STANDARD DENSITY	
<b>1D</b>	
.0050" (.127 mm)	3.7 to 5.0" (94 to 127 mm)
.0075" (.191 mm)	2.2 to 6.5" (56 to 165 mm)
.010" (.254 mm)	1.5 to 8.0" (38 to 203 mm)
.020" (.508 mm)	2.3 to 15.5" (58 to 394 mm)
<b>2D</b>	
.0050" (.127 mm)	3.7 to 4.6" (94 to 117 mm)
.0075" (.191 mm)	1.5 to 6.0" (38 to 152 mm)
.010" (.254 mm)	1.6 to 7.7" (41 to 196 mm)
.020" (.508 mm)	1.6 to 9.4" (41 to 239 mm)

Note: Specifications are subject to change. Working ranges are a combination of both the wide and high density fields.

## SAFETY CERTIFICATIONS DESIGNED FOR FCC, CE

## ROHS/WEEE COMPLIANT

## ISO CERTIFICATION

Certified ISO 9001:2008 Quality Management System

©2015 Microscan Systems, Inc. SP074G-EN-1013  
 Read Range and other performance data is determined using high quality Grade A symbols per ISO/IEC 15415 and ISO/IEC 15416 in a 25° C environment. For application-specific Read Range results, testing should be performed with symbols used in the actual application. Microscan Applications Engineering is available to assist with evaluations. Results may vary depending on symbol quality. **Warranty**—For current warranty information on this product, please visit [www.microscan.com/warranty](http://www.microscan.com/warranty).

# MICROSCAN®

**Microscan Systems Inc.**  
 Tel 425 226 5700 / 800 251 7711  
 Fax 425 226 8250

**Microscan Europe**  
 Tel 31 172 423360 / Fax 31 172 423366

**Microscan Asia Pacific**  
 Tel 65 6846 1214 / Fax 65 6846 4641

## www.microscan.com

Product Information: [info@microscan.com](mailto:info@microscan.com)  
 TechnicalSupport: [helpdesk@microscan.com](mailto:helpdesk@microscan.com)